

KBSI-240D

SIGNAL ISOLATOR

Provides an Isolated Interface
Between Non-Isolated Signal Sources
and Variable Speed
Motor Controls

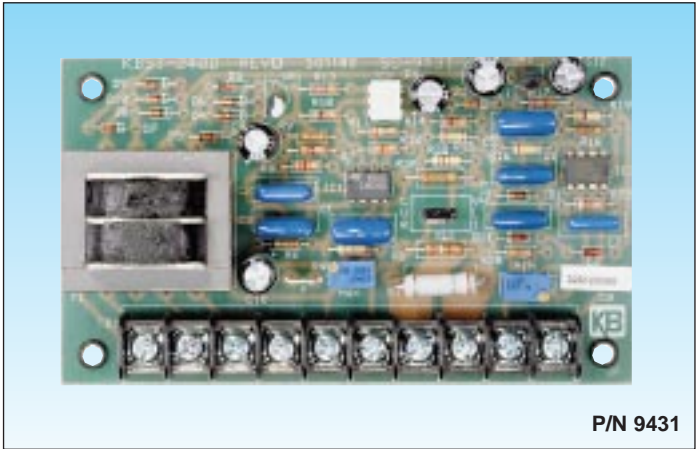

P/N 9431

STANDARD FEATURES

- Accepts Voltage or Current Inputs
- Operates on 115/230 VAC 50/60 Hz
- Multi-turn Trimpots for MIN & MAX

SPECIFICATIONS

AC Power Requirements115 or 230 VAC, 50/60Hz ⁽¹⁾
Signal Input Voltage ⁽²⁾0 – 25, 0 – 120, 0 – 550 VDC
Signal Input Current ⁽²⁾1 – 5, 4 – 20, 10 – 50 mA ⁽³⁾
Maximum Output Voltage10 Volts
Maximum Output Current10 mA
Range of “MIN” Trimpot± 3 Volts
Range of “MAX” Trimpot 0 – 2 Times the Input Voltage
With a Maximum of 10 Volts
Linearity ⁽⁴⁾± .1%
Temperature Drift ⁽⁴⁾4 mV Per °C
Temperature Operating Range0 – 50 °C

Notes:

1. To achieve full specifications, input voltage must be within ± 10% of nominal.
2. Floating (non-grounded) or grounded input signal may be used.
3. To change from 4–20 mA to 1–15 mA remove (use cutters) R3A. To convert to 10–50 mA, add a 150 ohm 1W resistor across terminals “5” and “6”.
4. Specifications are based on an output of 10 volts.

MECHANICAL SPECIFICATIONS

INCHES
[mm]

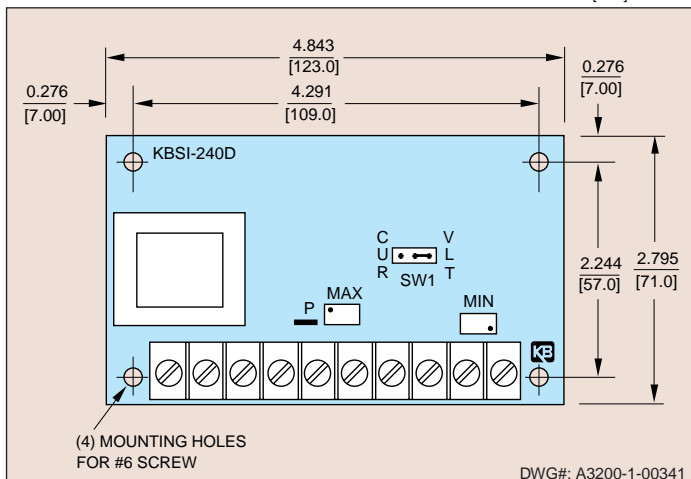

DESCRIPTION

The KBSI-240D Signal Isolator is used to isolate and condition DC voltage and current signals which are derived from transducers, microprocessors, motors and process controllers. The output of the Signal Isolator is connected to the input of any variable speed motor control with a voltage following input. The maximum output voltage of the Isolator is 10 volts, which is a linear function of the input signal.

The KBSI-240D is versatile since it can accommodate a wide range of input voltages (0 – 25, 0 – 120 and 0 – 550 VDC) and, in addition, a wide range of input current signals (4 – 20 mA, 10 – 50 mA and 1 – 5 mA). The built-in Voltage Current (“VLT/ CUR”) jumper is used to change the Signal Isolator from a voltage to a current input. In the current mode, the unit is factory calibrated so that a 4 – 20 mA input yields a 0 – 9 VDC output. The KBSI can also be controlled with a 5K ohm potentiometer in lieu of a signal input. The control is supplied with two multi-turn trimpots (MIN and MAX) which are used to scale the input and output signals to the desired level. The KBSI-240D can be powered with either a 115 or 230 VAC 50/60Hz power source. A complete instruction manual is supplied with each control.

KBSI-240D

SIGNAL ISOLATOR

Provides an Isolated Interface
Between Non-Isolated Signal Sources
and Variable Speed
Motor Controls

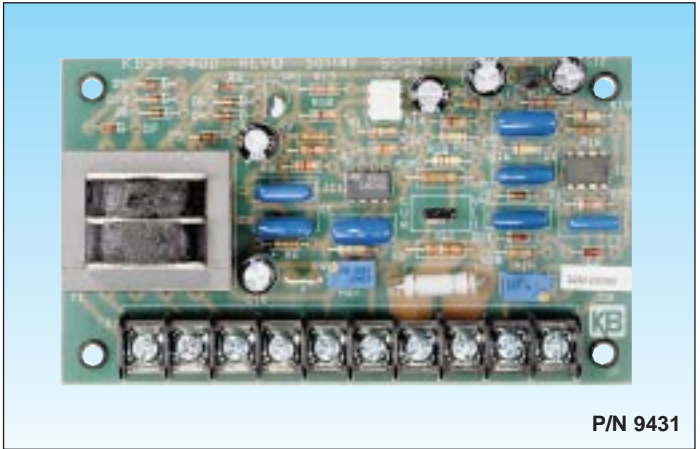

P/N 9431

STANDARD FEATURES

- Accepts Voltage or Current Inputs
- Operates on 115/230 VAC 50/60 Hz
- Multi-turn Trimpots for MIN & MAX

SPECIFICATIONS

AC Power Requirements115 or 230 VAC, 50/60Hz ⁽¹⁾
Signal Input Voltage ⁽²⁾0 – 25, 0 – 120, 0 – 550 VDC
Signal Input Current ⁽²⁾1 – 5, 4 – 20, 10 – 50 mA ⁽³⁾
Maximum Output Voltage10 Volts
Maximum Output Current10 mA
Range of “MIN” Trimpot± 3 Volts
Range of “MAX” Trimpot 0 – 2 Times the Input Voltage
With a Maximum of 10 Volts
Linearity ⁽⁴⁾± .1%
Temperature Drift ⁽⁴⁾4 mV Per °C
Temperature Operating Range0 – 50 °C

Notes:

1. To achieve full specifications, input voltage must be within ± 10% of nominal.
2. Floating (non-grounded) or grounded input signal may be used.
3. To change from 4–20 mA to 1–15 mA remove (use cutters) R3A. To convert to 10–50 mA, add a 150 ohm 1W resistor across terminals “5” and “6”.
4. Specifications are based on an output of 10 volts.

MECHANICAL SPECIFICATIONS

INCHES
[mm]

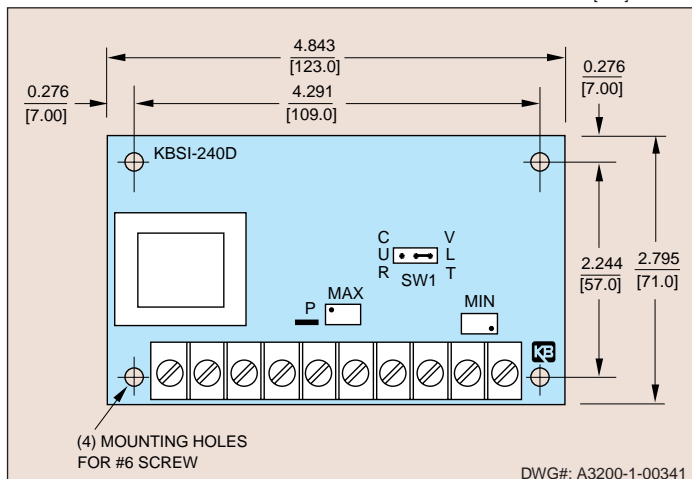

DESCRIPTION

The KBSI-240D Signal Isolator is used to isolate and condition DC voltage and current signals which are derived from transducers, microprocessors, motors and process controllers. The output of the Signal Isolator is connected to the input of any variable speed motor control with a voltage following input. The maximum output voltage of the Isolator is 10 volts, which is a linear function of the input signal.

The KBSI-240D is versatile since it can accommodate a wide range of input voltages (0 – 25, 0 – 120 and 0 – 550 VDC) and, in addition, a wide range of input current signals (4 – 20 mA, 10 – 50 mA and 1 – 5 mA). The built-in Voltage Current (“VLT/ CUR”) jumper is used to change the Signal Isolator from a voltage to a current input. In the current mode, the unit is factory calibrated so that a 4 – 20 mA input yields a 0 – 9 VDC output. The KBSI can also be controlled with a 5K ohm potentiometer in lieu of a signal input. The control is supplied with two multi-turn trimpots (MIN and MAX) which are used to scale the input and output signals to the desired level. The KBSI-240D can be powered with either a 115 or 230 VAC 50/60Hz power source. A complete instruction manual is supplied with each control.

PENTA KB POWERTM

Distributed by ELECTRO SALES CO., INC. Phone: +1 (617) 666-0500 ~ FAX +1 (617) 628-2800