

KBET-240D

Frequency to Analog Tachometer
and Follower

Converts a Pulse Input Signal Into Individual
Isolated Tachometer Feedback
and Follower Output Signals

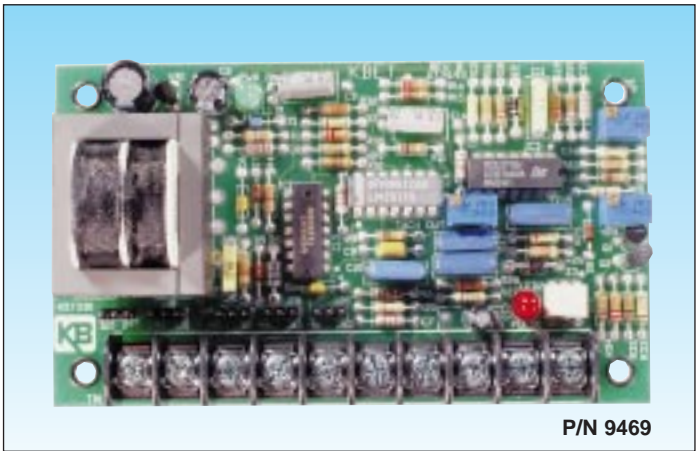

P/N 9469

STANDARD FEATURES

- Sensor Type: Open Collector (Hall, Magnetic, Inductive, Opto) and Two-Wire Inductive
- AC Line Voltage 115 or 230 VAC
- LED “Pulse” Indicator (Red)
- LED “Power On” Indicator (Green)

TRIMPOT ADJUSTMENTS

- Tachometer Output (TACH)
- Follower Minimum Output (MIN)
- Follower Maximum Output (MAX)

SPECIFICATIONS

AC Line Input Voltage	115/230 ± 15% VAC – 50/60Hz
Tachometer Output Voltage Range (VDC)	0 – 17
Tachometer Output Trimpot Range (Millivolts Per Pulses/Sec.)	3 – 8
Tachometer Output Trimpot Range (Volts at 1000 RPM and 60 Pulses/Sec)	3.5 – 10.0
Load Regulation (Set Speed) (20:1 Speed Range) (%)	1
Load Regulation (Set Speed) (30:1 Speed Range) (%)	2
Follower MIN. Trimpot Output Range (VDC)	(-4) – (+4)
Follower MAX. Trimpot Output Range (VDC)	0 – 10
Follower MAX. Trimpot Output Range (Millivolts Per Pulses/Sec.)	0 – 8
Follower Linearity (30:1 Speed Range) (%)	2
Input Frequency Range “Open Collector” (Pulses/Sec)	60 – 10,000
Input Frequency Range 2-Wire Inductive Pickup (Pulses/Sec.)	100 – 3,000
Ambient Temperature Range (°C)	0 – 50

DESCRIPTION

The KBET-240D is designed to accept a pulse input, which is produced by most “open collector” (Hall, magnetic, inductive and opto) or 2-wire inductive pickups, and to create two independent isolated output signals. The Tachometer Output is normally used for tachometer feedback. The Follower Output is used to drive a second control in a master/slave system. If tachometer feedback is not required on the master motor, the Tachometer Output can be used to drive an additional slave.

Two LED indicators are incorporated into the KBET circuitry. The “Power On” LED is used to indicate that the unit has AC power, and the “Pulse” LED is used as a diagnostic to verify the presence of an encoder input.

Jumper selections allow for setting the AC input voltage (115/230 VAC) and the sensor type. The KBET is factory calibrated to 7V/1000 RPM (60 pulses/rev pickup) for the Tachometer Output and 10 VDC per 1800 RPM for the Follower Output. Multiturn trimpots are provided to tailor the Tachometer and Follower Outputs for specific applications.

MECHANICAL SPECIFICATIONS

INCHES
[mm]

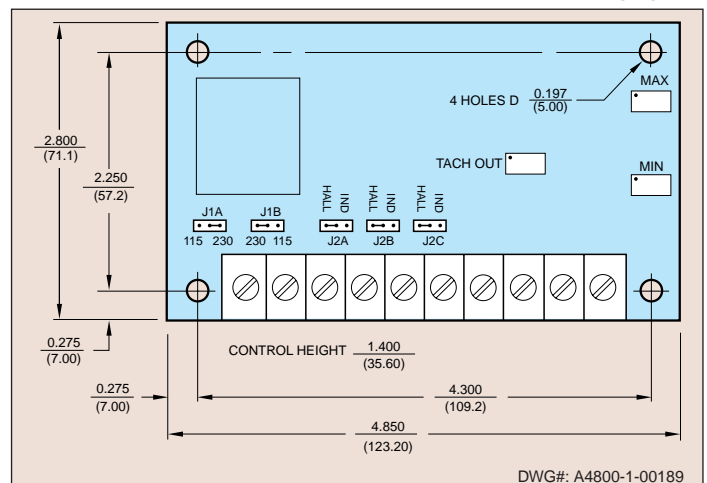

DWG#: A4800-1-00189

BLOCK DIAGRAM MASTER/SLAVE WITH TACHOMETER FEEDBACK

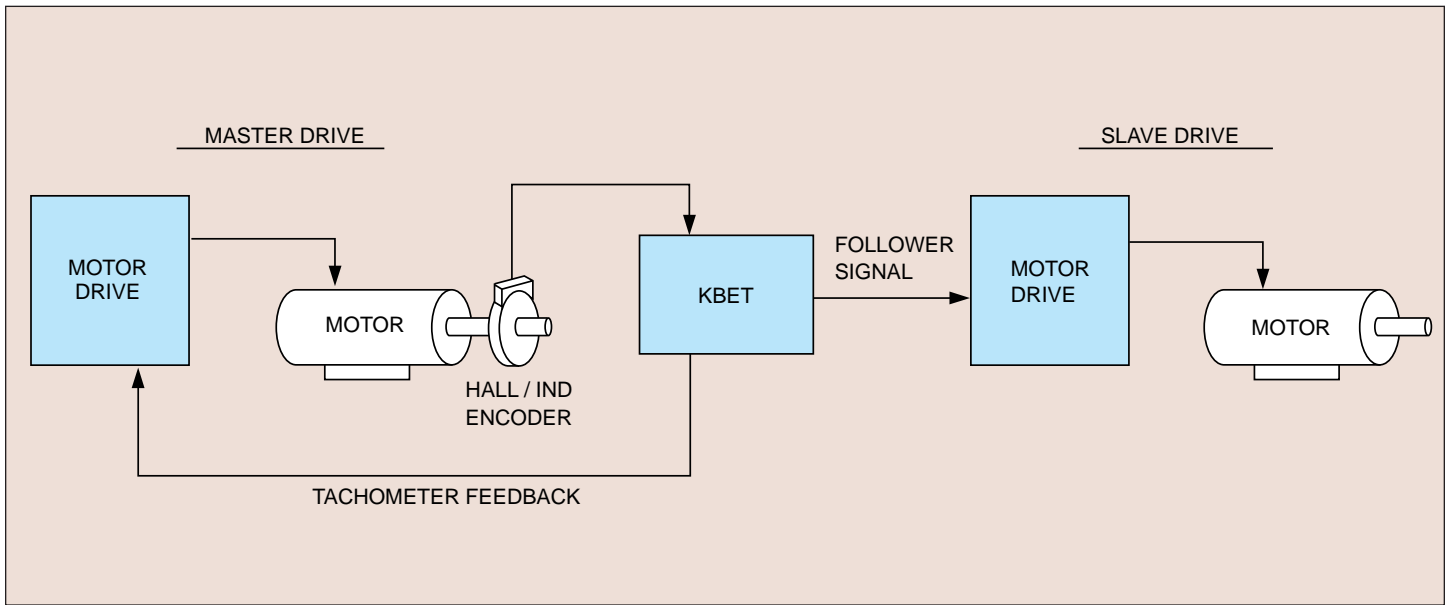

MASTER/SLAVE WITH TACHOMETER FEEDBACK

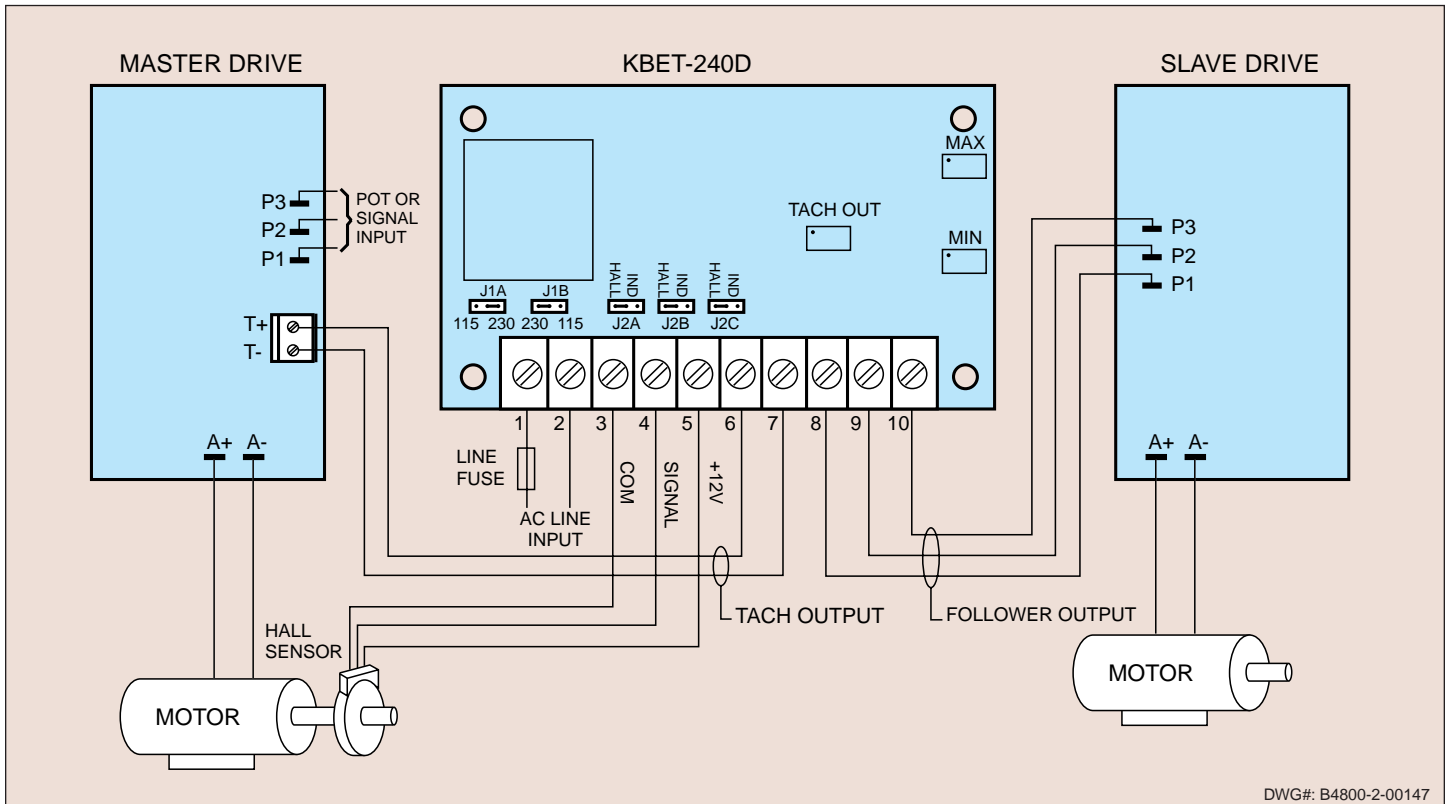

DWG#: B4800-2-00147

