

KBCC-255

Chassis Mount Variable Speed DC Motor Control
For Shunt Wound and PM Motors

RATED – 5 Hp @ 230 VAC – 50/60 Hz

Patented Overload Circuit

TYPICAL APPLICATIONS

- Transfer Pumps • Door Openers
- Tapping Machines • Indexers • Conveyors
- Feeders • Robotics • Screen Presses

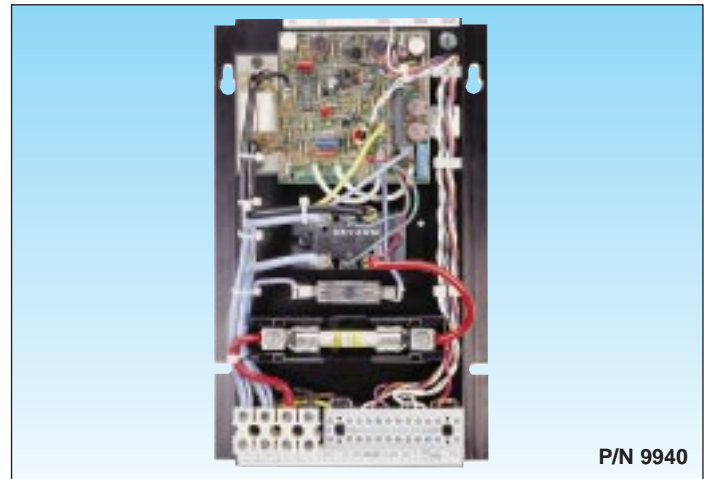

STANDARD FEATURES

- Built-in Armature and Control Circuit Fuses
- Trimpots: MIN, MAX, IR, CL, ACCEL, DECEL
- MOV Transient Protection
- Armature or Tachometer Feedback
- Voltage Following
- Inhibit™ and Enable Circuit
- CL LED Indicator

SPECIFICATIONS

Speed Range (Ratio)	50:1
Load Regulation – Armature Feedback (0 – Full Load, 50:1 Speed Range) (% Base Speed)	1*
Load Regulation – Tachometer Feedback (0 – Full Load, 50:1 Speed Range) (% Set Speed)	1*
Line Voltage Regulation – Armature Feedback (At Full Load, ± 10% Line Variation) (% Base Speed)....	1/2*
Line Voltage Regulation – Tachometer Feedback (At Full Load, ± 10% Line Variation) (% Set Speed)	1/2*
Control Linearity (% Speed vs. Dial Rotation)	2
CL/Torque Range (% Full Load)	0 – 200
ACCEL/DECEL Time Range (0 – Full Speed) (Secs.)	1 – 10
MIN Speed Trimpot Range (% Full Speed)	0 – 30*
MAX Speed Trimpot Range (% Full Speed)	50 – 110*
IR Compensation Trimpot Range (At Specified Full Load) (Volts)	0 – 24
Maximum Allowable Ambient Temperature (At Full Rating °C/°F)	45/113
Tachometer Feedback Input Volts (Per 1000 RPM) (VDC).....	7/50

* Performance is for SCR rated PM motors only. Lower performance can be expected with other motor types. Factory setting is for 3% load regulation. To obtain superior regulation, see instruction manual. Other factory trimpot settings are as follows: CL-150% FL, ACCEL-3 secs., MIN-(0)-speed, MAX-full speed and IR-3 volts.

DESCRIPTION

The KBCC™ 5-Hp chassis control utilizes the KBMM™ modular control to provide a reliable variable speed SCR drive for PM and Shunt DC motors. The KBCC is a full-featured control offering adjustable linear acceleration and deceleration functions. In addition, the control contains Enable (close to run) and Inhibit™ (close to stop) circuitry. An exclusive feature found only in KB drives is Auto Inhibit®. It provides a smooth, safe start during rapid switching of the AC line.

The KBCC-255 is factory wired for armature feedback which, for most applications, provides excellent performance. For superior performance, the control can easily be converted to DC tachometer feedback. Provision is made for both 7V and 50V per 1000 RPM tachs. Reliability is enhanced by incorporating a separate 42.5 AMP DC power bridge and both armature and control circuit fusing.

The KBCC is built on a rugged aluminum heatsink, which is compact in size and easy to install. The control is supplied with a remote 5K ohm potentiometer. However, it can also be operated in a voltage following mode by supplying 0 - 9VDC *isolated* analog voltage to terminals P2 (+) and F-. Individual adjustment trimpots are provided for minimum speed (MIN), maximum speed (MAX), IR compensation (IR), current limit (CL), acceleration start (ACCEL) and deceleration (DECEL).

ELECTRICAL RATINGS

Model	AC Line Voltage (VAC) ±15% (50/60 Hz)	Max. AC Load Current (RMS Amps)	Max. DC Load Current (Avg. Amps)	Maximum Horsepower [Hp, (KW)]	Fuse Size (Amps)
KBCC-255	230	38	26	5, (3.8)	40

* CE Compliance Requires CE Approved RFI Filter

FEATURES & FUNCTIONS

- (1) Rugged Aluminum Heatsink
- (2) KBMM Speed Control
- (3) Power Bridge Module
- (4) Control Fuse
- (5) Armature Fuse
- (6) Barrier Terminal Block
- (7) Trimpots: MIN, MAX, ACCEL, DECEL, IR and CL
- (8) Keyhole slots facilitate mounting
- (9) CL LED Indicator

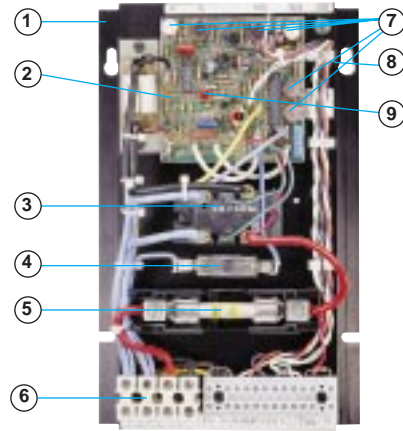

MECHANICAL SPECIFICATIONS

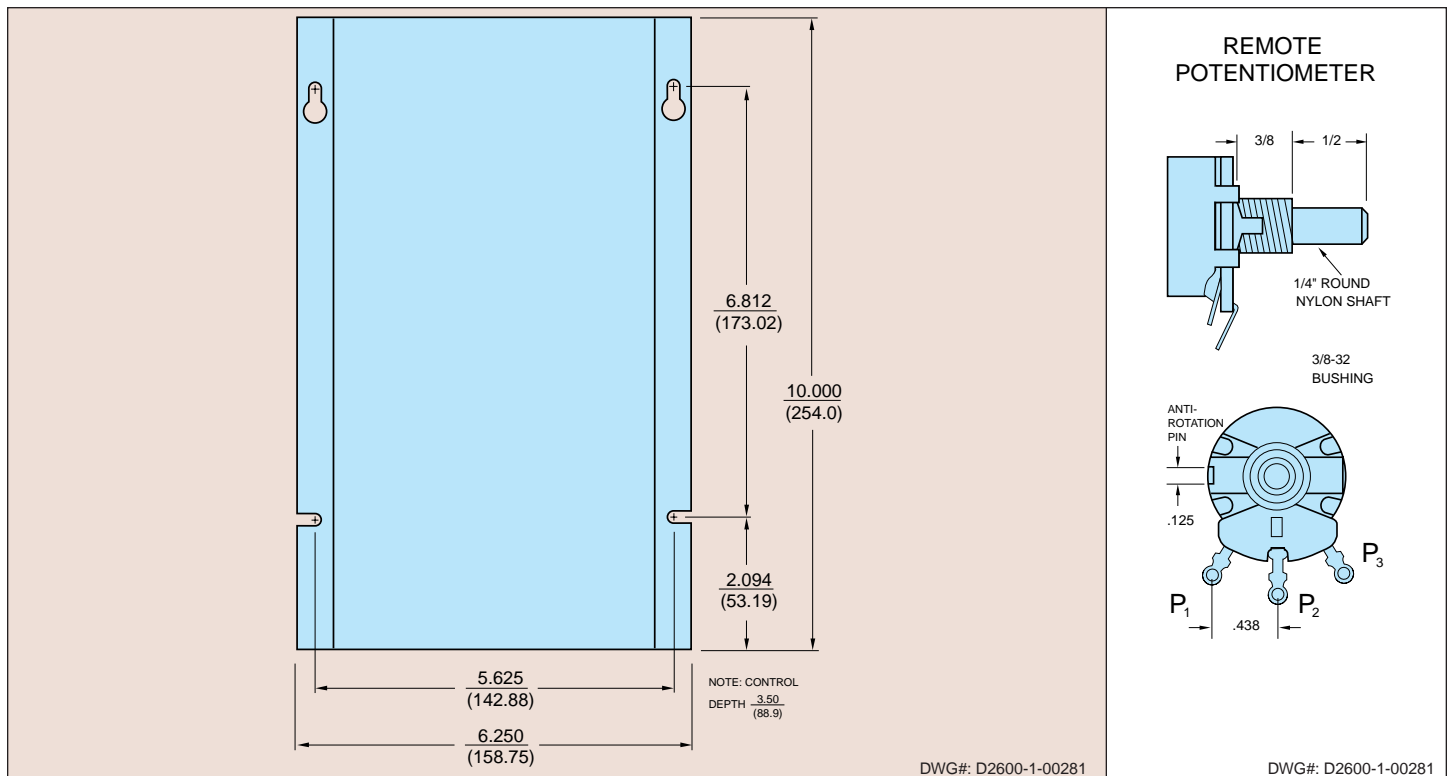

CONNECTION DIAGRAM

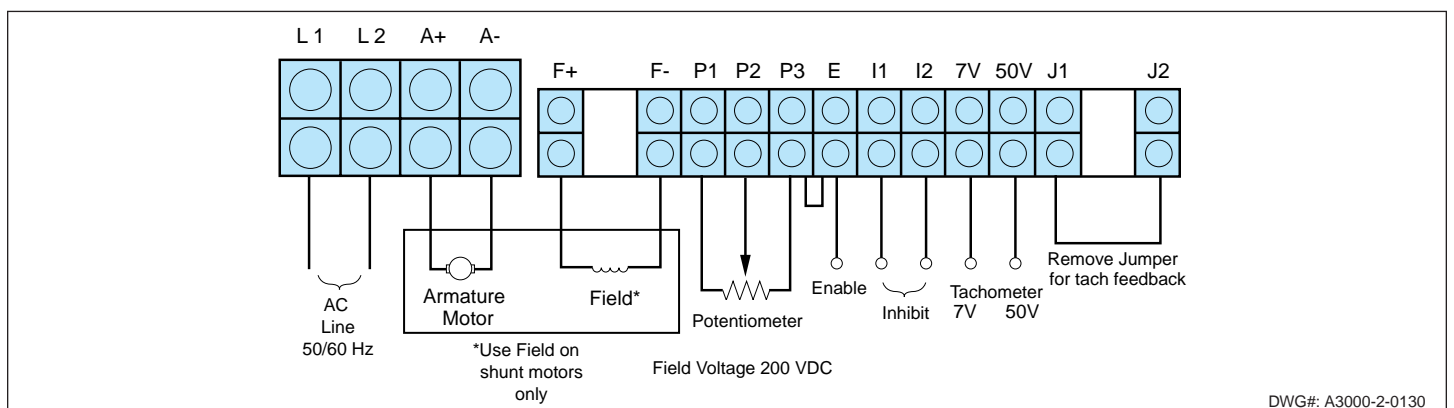

© 1997 KB Electronics, Inc.



KB ELECTRONICS, INC.
 distributed by ELECTRO SALES CO., INC.
 100 Fellsway West, Somerville MA 02145 U.S.
 Phone: +1 (617) 666-0500 ~ Fax: +1 (617) 628-2800
 www.electrosales.com/kb