

KBCC-240D

CHASSIS MOUNT PENTA-DRIVE™

Variable Speed-Torque SCR DC Motor Control
for Shunt Wound and PM Motors

ONE MODEL COVERS

1/50 – 1 Hp @ 115 VAC – 50/60 Hz

1/25 – 2 Hp @ 230 VAC – 50/60 Hz

TYPICAL APPLICATIONS

- Packaging Machines • Pumps • Feeders
- Exercise Equipment • Conveyors

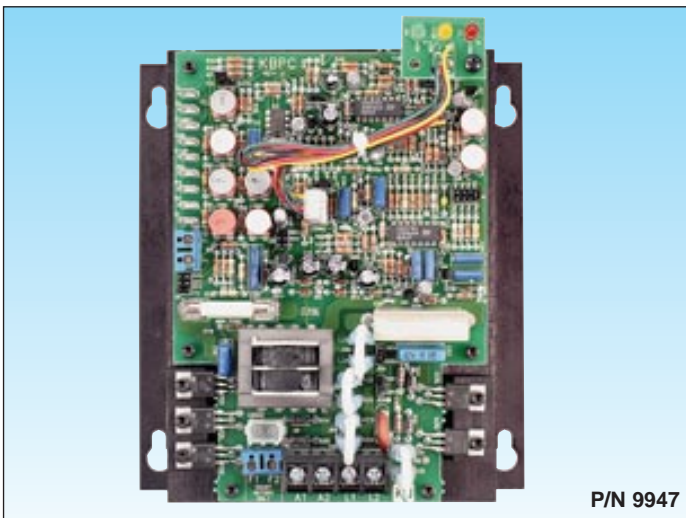

STANDARD FEATURES

- Electronic Overload Protection
 - Built-in Armature Fusing[▲]
 - LED's for "Power On," "Overload" and "Stop"
 - Electronic Start-Stop
- [▲] Fuse supplied separately

JUMPER SELECTABLE FEATURES

- Control Mode: **Speed**, Torque
 - DC Current Output (ADC): 2.5, 5.0, 7.5, **10**
 - AC Line Voltage (VAC-50/60 Hz): 115, **230**
 - DC Armature Voltage (VDC): 90, **180**
 - Feedback Type: **Armature**, Tachometer
 - Tachometer Voltage[▲] (VDC): **7**, 20/30, 50
 - Timed Current Limit: **TCL**, NTCL
- Bold figure indicates factory setting. [▲] Per 1,000 RPM

TRIMPOT ADJUSTMENTS

- Minimum Speed (MIN)
- Current Limit (CL)
- Acceleration (ACCEL)
- Timed Current Limit (TCL)
- Maximum Speed (MAX)
- IR Compensation (IR)
- Deceleration (DECEL)
- Jog Speed (JOG)[▲]

[▲] Used with Run-Stop-Jog option.

OPTIONAL FEATURES

- Forward-Brake-Reverse Switch (P/N 9339)
- Run-Stop-Jog Switch (P/N 9340)
- Signal Isolator, KBSI-240D (P/N 9431)
- On/Off AC Line Switch (P/N 9341)
- Electronic Pot, KBEP-240D (P/N 9108)
- Anti Plug Reversing Module (P/N 9378)
- Auto/Manual Kit (P/N 9377)

DESCRIPTION

The KBPC state-of-the-art electronics include short circuit and transient protection to provide the ultimate in reliability. Electronics overload protection is also provided, which prevents motor burnout and demagnetization of PM motors. The control can be operated in either the speed or torque mode via a jumper selection. The current range, which is also jumper selectable, eliminates the necessity for calibration of IR compensation and current limit for most applications. The KBCC also contains jumper selections for AC line voltage (115/230), DC armature voltage (90/180) and feedback type (armature/tachometer).

Standard features include Armature Fusing, Electronic Start/Stop and LED Indicator Array for "Power On," "Stop" and "Overload."

Although the KBCC is factory set for most applications, a variety of trimpots allows adjustment of the following parameters: MIN and MAX speed, Acceleration, Deceleration, Current Limit, IR Comp, and Timed Current Limit. The drive offers the ultimate in flexibility with the availability of several customer installed options. These include: Forward-Brake-Reverse, Run-Stop-Jog, On/Off AC Line Switch, Anti-Plug Reversing Module, Input Signal Isolation, and Electronic Potentiometer. A complete instruction manual is included.

* CE Compliance Requires KBRF-200 RFI Filter

SPECIFICATIONS

Parameter	Specification	Factory Setting	Parameter	Specification	Factory Setting
AC Line Voltage Regulation (% Base Speed)	±0.5	—	Horsepower Range at 115 VAC Line (Hp) [KW]	1/50–1, [.015-.75]	—
Current Ranges (ADC)	2.5, 5, 7.5, 10	10	Horsepower Range at 230 VAC Line (Hp) [KW]	1/25–2, [.03–1.5]	—
ACCEL and DECEL Ranges (Seconds)	0.1–15	1	Armature Voltage Range at 115 VAC Line (VDC)	0–130*	—
MIN SPEED Range (% Base Speed)	0–30	0	Armature Voltage Range at 230 VAC Line (VDC)	0–220*	180
MAX SPEED Range (% Base Speed)	60–140	100	Field Voltage at 115 VAC Line (VDC)	100/50**	—
IR COMP Range at 115 VAC Line (VDC)	0–15	4	Field Voltage at 230 VAC Line (VDC)	200/100**	—
IR COMP Range at 230 VAC Line (VDC)	0–30	8	Ambient Temperature Range (°C)	0–50	—
CL Range (% Range Setting)	0–200	150	Speed Range (Ratio)	50:1	—
TIMED CL Range (Seconds)	0.5–15	7	Load Regulation, Arm. Feedback (% Base Speed)	± 1	—
Voltage Following Linearity (% Base Speed)	± 0.5	—	Load Regulation, Tach. Feedback (% Set Speed)	± 1	—
AC Line Voltage (VAC ± 10%, 50/60 Hz)	115 or 230	230			

NOTES: *Maximum recommended output voltage is 90 VDC for 115 VAC and 180 VDC for 230 VAC. Exceeding these output voltages may cause a reduction in load regulation performance. **For shunt wound motor with lower voltage field, use L₁ and F₁ connection.

ELECTRICAL RATINGS

Model Number	KB Part Number	AC Line Voltage (VAC) ± 10% 50/60 Hz	Motor Voltage (VDC)	Max. AC Load Current (RMS Amps)	Max. DC Load Current (DC Amps)	Maximum Horsepower Hp, (KW)	Field Voltage** (Volts DC)	
							Terminals F ₁ , F ₂	Terminals F ₁ , L ₁
KBCC-2400	9947	115	0 – 130	15.0	10.2	1, (.75)	100	50
		230	0 – 220 0 – 130*	15.0	10.2	2, (1.5)	200	100

*Stepdown operation (90 VDC motors with 230 VAC input) can cause a reduction in motor performance. **Shunt motors only

MECHANICAL SPECIFICATIONS INCHES [mm]

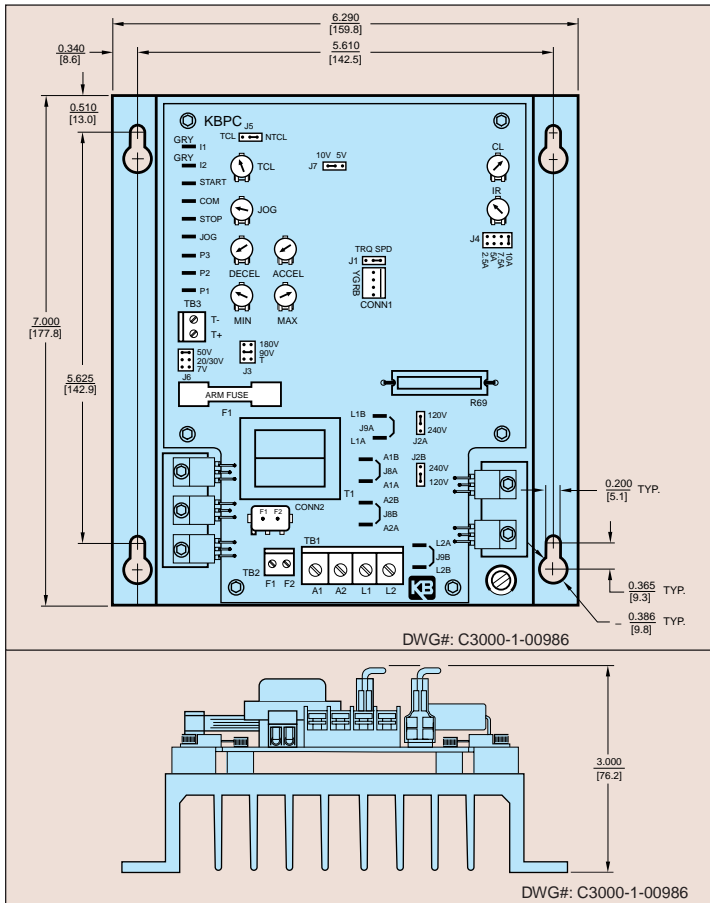

CONNECTION DIAGRAM

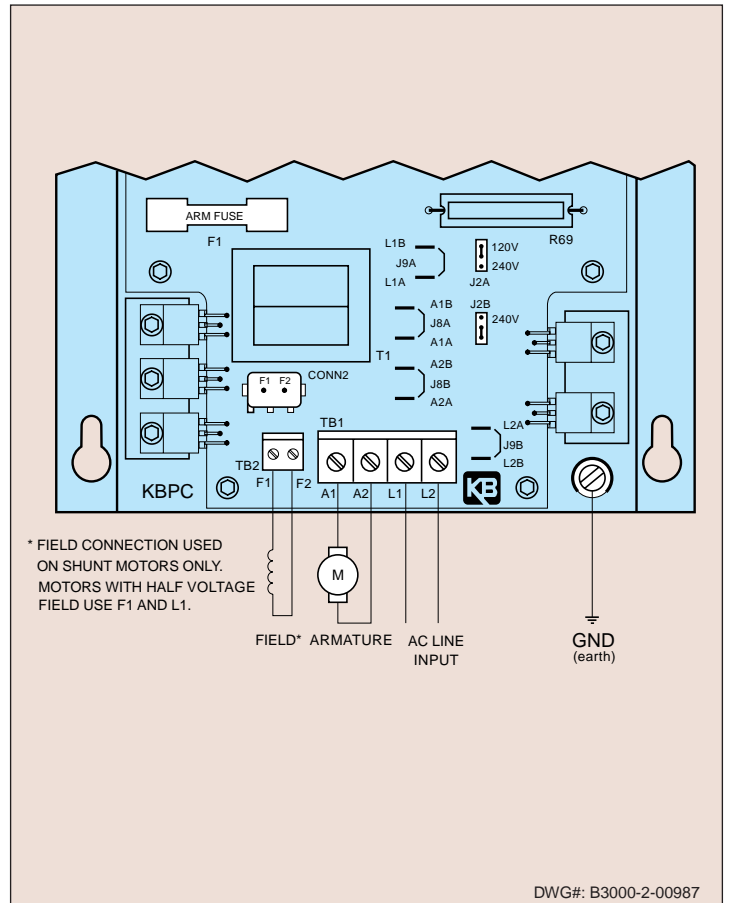

© 1997 KB Electronics, Inc.



KB ELECTRONICS, INC.
 distributed by ELECTRO SALES CO., INC.
 100 Fellsway West, Somerville MA 02148 U.S.
 Phone: +1 (617) 666-0500 ~ Fax: +1 (617) 628-2800
 www.electrosales.com/kb